

CLOW
VALVE CO.

ClowValve.com



EDDY FIRE HYDRANT MODEL F-2640 / F-2641

AWWA C502 • UL LISTED* • FM APPROVED •
250 PSI RATED • BOTH DRAIN AND DRAINLESS
FEATURES AVAILABLE • 10-YEAR LIMITED WARRANTY •
SAME RELIABLE DESIGN SINCE 1875

*5 1/4 ONLY UL/FM



Clow Valve is a division of McWane, Inc.

For Generations

EDDY FIRE HYDRANT

The Eddy hydrant is a classic design built to provide unsurpassed fire protection and an appealing aesthetic. Since 1875, the Eddy hydrant has been reliably serving communities and firefighters across the country.

The Eddy opens easily and quickly under pressure, ensuring time-tested performance year after year.

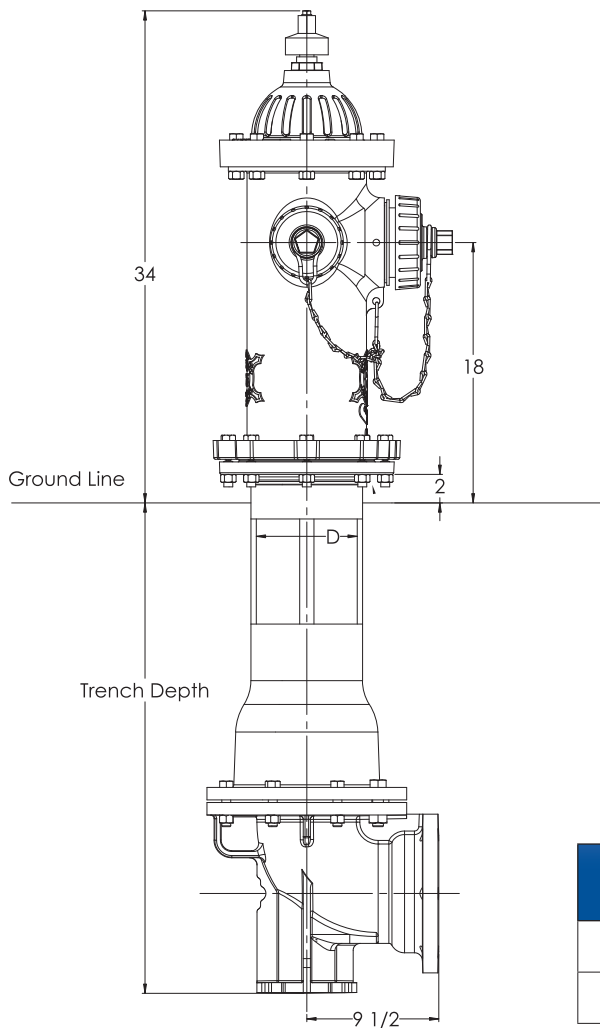

HYDRANT VALVE SIZE	D
4 1/2	6 1/4
5 1/4	7 1/16

ENGINEERING FEATURES

THREADED NOZZLES
Easily replaced locking set screw to hold nozzle in place. O-ring seal.

MAIN VALVE CLOSSES AGAINST PRESSURE
Reduces valve seat damage and lowers the potential for water hammer.

MAIN VALVE OPENS WITH PRESSURE
Water assists in opening the valve, making operation easier, faster, and positive.

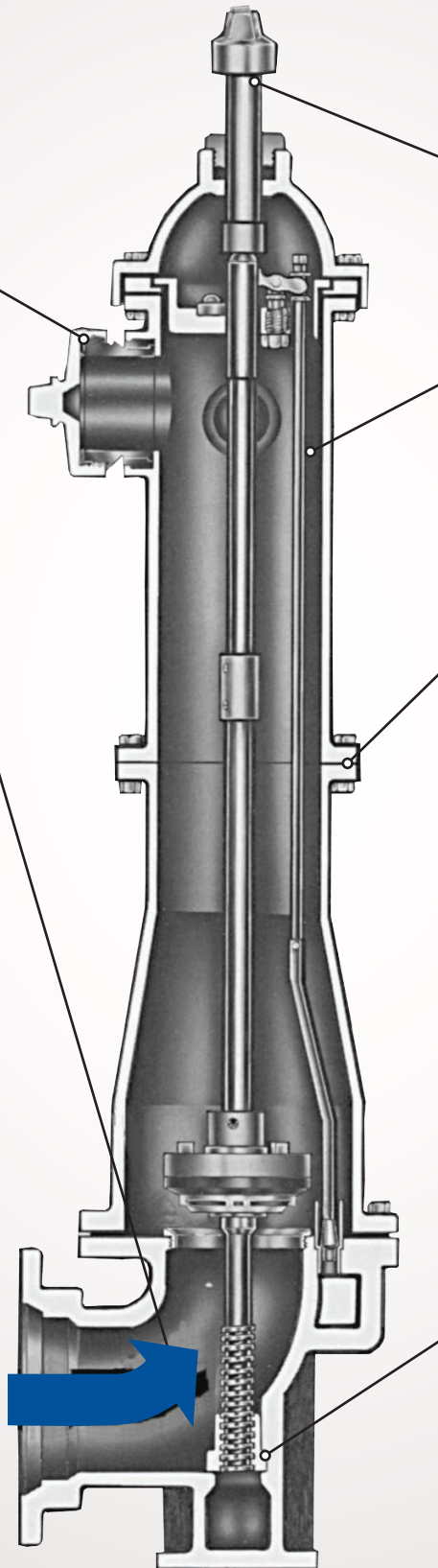

RISING STEM
Indicating feature lets you know position of main valve.

INDEPENDENT DRAIN
Allows plugging of drain without disassembly of hydrant.

BREAK FLANGE DESIGN
Breakaway parts shear cleanly above the barrel, reducing nozzle section damage or opening of the main valve.

STEM NUT BELOW GROUND LINE
Maintains positive shut off of main valve after traffic damage. Does not depend on water pressure. Never needs lubrication. All copper alloy construction.

F-2640

EDDY HYDRANT PARTS ASSEMBLY

WITH DRAIN ASSEMBLY

PART NO.	DESCRIPTION	MATERIAL	QTY.
1	Hold Down Bolt	Stainless Steel	1
2	Operating Nut	Cast Iron	1
3	Packing Gland	Copper Alloy	1
4	O-Ring w/ Adapter	Optional	1
4	Packing	Rubber	1
5	Cover Bolts & Nuts	Stainless Steel	8
6	Cover	Cast Iron	1
7	Flange O-Ring	Rubber	2
8	Swivel Ring	Cast Iron	1
9	Hose Nozzle O-Ring	Rubber	2
10	Hose Nozzle	Copper Alloy	2
11	Hose Noz. Gasket	Neoprene	2
12	Hose Noz. Cap	Cast Iron	2
13	Steamer Nozzle O-Ring	Rubber	1
14	Steamer Nozzle	Copper Alloy	1
15	Steamer Nozzle Gasket	Neoprene	1
16	Steamer Nozzle Cap	Cast Iron	1
17	Nozzle Section	Cast Iron	1
18	Nozzle Section O-Ring	Rubber	1
19	Break Flange Bolts & Nuts	Yellow Zinc Steel	8
20	Break Flange	Cast Iron	2
21	Standpipe	Ductile Iron	1
22	Bottom Bolts & Nuts	Stainless Steel	8
23	Bottom O-Ring	Rubber	1
24	Seat Ring	Copper Alloy	1
25	Drain Cup	Copper Alloy	1
26	Hydrant Bottom	Ductile Iron	1
27	Hydrant Bottom Nut	Copper Alloy	1
28	Retaining Clip	Stainless Steel	1
29	Upper Stem	Steel & Copper Alloy	1
30	Stem Coupling	Cast Iron	1
31	Stem Coupling Pins	Stainless Steel	3
32	Middle Stem	Steel	1
33	Lower Stem	Copper Alloy	1
34	Valve Plate	Cast Iron	1
35	Valve Rubber	Rubber	1
36	Thrust Washer	Copper Alloy	2
37	Lower Stem O-Ring	Rubber	2
38	Snap Ring	Stainless Steel	1
39	Throttling Ring	Copper Alloy	1
40	Retaining Nut	Copper Alloy	1
41	Drain Valve Rubber	Rubber	1
42	Drain Valve Backer	Copper Alloy	1
43	Drain Rod	Steel	1
44	Clevis Nut	Copper Alloy	1
45	Drain Support	Cast Iron	1
46	Lever Pin	Copper Alloy	1
47	Clevis	Copper Alloy	1
48	Cotter Pin	Copper Alloy	2
49	Drain Lever	Copper Alloy	1
50	Drain Spool	Copper Alloy	1
51	Jam Nut	Copper Alloy	1
	Chain	Zinc Plated Steel	3

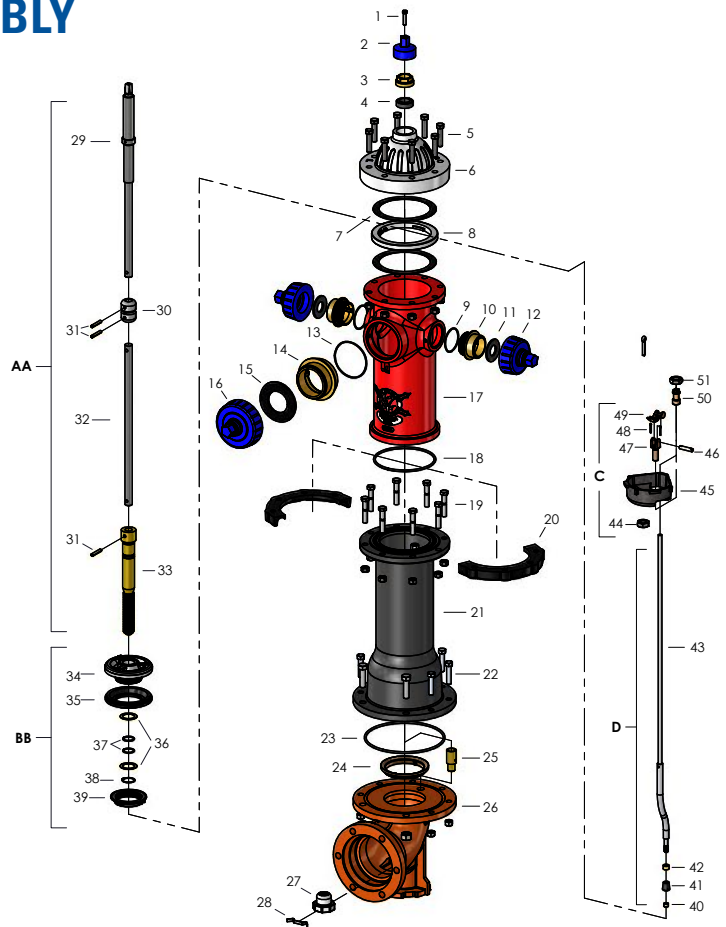

WORKING PRESSURE: 250 PSI

ASSEMBLY	CONSISTING OF PARTS
AA	Main Stem 29-33
BB	Hydrant Valve 34-39
C	Drain Support 44-49
D	Drain Valve 40-43, 50-51
EE	Complete Valve and Stem Assemblies AA & BB

RECOMMENDED SPECIFICATIONS

- Hydrant shall be center-stem type and in accordance with AWWA Standard C502.
- Hydrant shall be compression type with the main valve opening with the water pressure and have a rising stem to positively indicate open or closed position.
- Hydrant shall be furnished with frangible flange and stem coupling at the ground line. Frangible bolts available upon request.
- Copper alloy stem threads shall be located below the main valve to eliminate necessity of lubrication; main valve will remain mechanically closed in case of damage to hydrant.
- Hydrant shall have minimum valve opening of either 4 1/2" or 5 1/4"; shoe inlet of 4" or 6".
- Hydrant shall be designed to permit removal of all working parts without special tools or wrenches.
- Hydrant shall be the Eddy hydrant, manufactured by Clow Valve Company.

F-2641

EDDY HYDRANT PARTS ASSEMBLY — NO DRAIN

FOR PROTECTION AGAINST CROSS CONNECTION

PART NO.	DESCRIPTION	MATERIAL	QTY.
1	Hold Down Bolt	Stainless Steel	1
2	Operating Nut	Cast Iron	1
3	Packing Gland	Copper Alloy	1
4	O-Ring w/ Adapter	Optional	1
4	Packing	Rubber	1
5	Cover Bolts & Nuts	Stainless Steel	8
6	Cover	Cast Iron	1
7	Flange O-Ring	Rubber	2
8	Swivel Ring	Cast Iron	1
9	Hose Nozzle O-Ring	Rubber	2
10	Hose Nozzle	Copper Alloy	2
11	Hose Noz. Gasket	Neoprene	2
12	Hose Noz. Cap	Cast Iron	2
13	Steamer Nozzle O-Ring	Rubber	1
14	Steamer Nozzle	Copper Alloy	1
15	Steamer Nozzle Gasket	Neoprene	1
16	Steamer Nozzle Cap	Cast Iron	1
17	Nozzle Section	Cast Iron	1
18	Nozzle Section O-Ring	Rubber	1
19	Break Flange Bolts & Nuts	Yellow Zinc Steel	8
20	Break Flange	Cast Iron	2
21	Standpipe	Ductile Iron	1
22	Bottom Bolts & Nuts	Stainless Steel	8
23	Bottom O-Ring	Rubber	1
24	Seat Ring	Copper Alloy	1
25	Hydrant Bottom	Ductile Iron	1
26	Hydrant Bottom Nut	Copper Alloy	1
27	Retaining Clip	Stainless Steel	1
28	Upper Stem	Steel & Copper Alloy	1
29	Stem Coupling	Cast Iron	1
30	Stem Coupling Pins	Stainless Steel	3
31	Middle Stem	Steel	1
32	Lower Stem	Copper Alloy	1
33	Valve Plate	Cast Iron	1
34	Valve Rubber	Rubber	1
35	Thrust Washer	Copper Alloy	2
36	Lower Stem O-Ring	Rubber	2
37	Snap Ring	Stainless Steel	1
38	Throttling Ring	Copper Alloy	1
	Chain	Zinc Plated Steel	3

WORKING PRESSURE: 250 PSI

ASSEMBLY	CONSISTING OF PARTS
AA	Main Stem 28-32
BB	Hydrant Valve 33-38
EE	Complete Valve and Stem Assemblies AA & BB

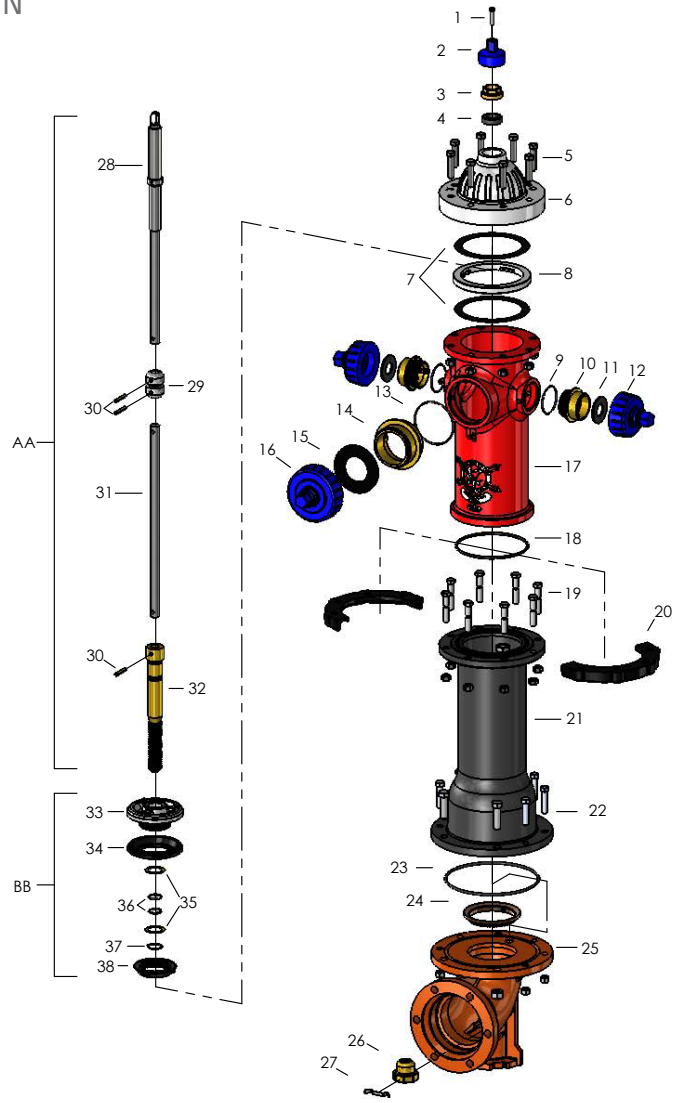

RECOMMENDED SPECIFICATIONS

- Hydrant shall be center-stem type and in accordance with AWWA Standard C502.
- Hydrant shall be compression type with the main valve opening with the water pressure and have a rising stem to positively indicate open or closed position.
- Hydrant shall be furnished with frangible flange and stem coupling at the ground line.
- Copper alloy stem threads shall be located below the main valve to eliminate necessity of lubrication; main valve will remain mechanically closed in case of damage to hydrant.
- Hydrant shall have minimum valve opening of either 4 1/2" or 5 1/4"; shoe inlet of 4" or 6".
- Hydrant shall be designed to permit removal of all working parts without special tools or wrenches.
- Hydrant shall be without a drain to prevent the possibility of cross connection.
- Hydrant shall be the Eddy hydrant, manufactured by Clow Valve Company.

PATRIOT HYDRANT CHECK VALVE

GUARD YOUR WATER SYSTEM FROM ACCIDENT OR ATTACK

Threats to the water supply can come from either accidental or deliberate acts. Our nation's water superintendents have safeguarded nearly all of the access points to our drinking water. At this time, one critical access point is left unprotected — the fire hydrant.

The Patriot hydrant check valve prevents reverse flow through the fire hydrant, safely protecting our drinking water while providing a full-port unobstructed waterway that allows firefighters access to the water they need when they need it.

Unlike locks and special external devices, the Patriot is installed underground, which prevents tampering and allows the hydrant to be operated the moment the firefighters arrive on the scene. The Patriot can be installed on any 6" mechanical joint connection, ensuring compatibility with all hydrant brands — providing the flexibility and cost-effectiveness you demand.

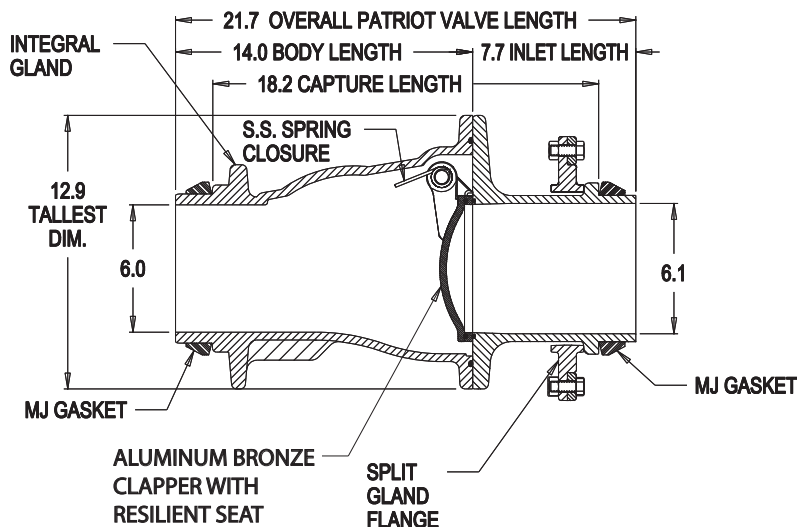

RECOMMENDED SPECIFICATIONS (OPTIONAL)

1. The check valve shall be manufactured to all of the testing and performance standards of AWWA C508 and AWWA C550. The check valve shall be designed for 250 psi working pressure and tested to 500 psi hydrostatic pressure.
2. The check valve shall be a standalone unit able to be positively restrained to any 6" mechanical joint fire hydrant shoe.
3. The check valve shall be ductile iron ASTM Standard A536 (70-50-05), with NSF-approved fusion-bonded epoxy coating (interior/exterior).
4. The check valve shall be lead free, with no exposed lead-bearing surfaces.
5. The check valve shall have an unobstructed waterway. No reduction of port or redirection of flow will be allowed.
6. The seat shall be retained via a double dove tail o-ring, retaining groove design to ensure a positive seal.
7. The check valve shall incorporate integral positive restraint connections that maintain a restrained connection between the fire hydrant and the gate valve.
8. The check valve shall incorporate a stainless steel spring that hastens positive closure and prevents water hammer.
9. All fasteners shall be 304 stainless steel, and all interior rubber components shall be EPDM rubber.
10. The check valve shall be produced with no less than 80% post consumer recycled content while being cast, manufactured, assembled, and tested in the United States.

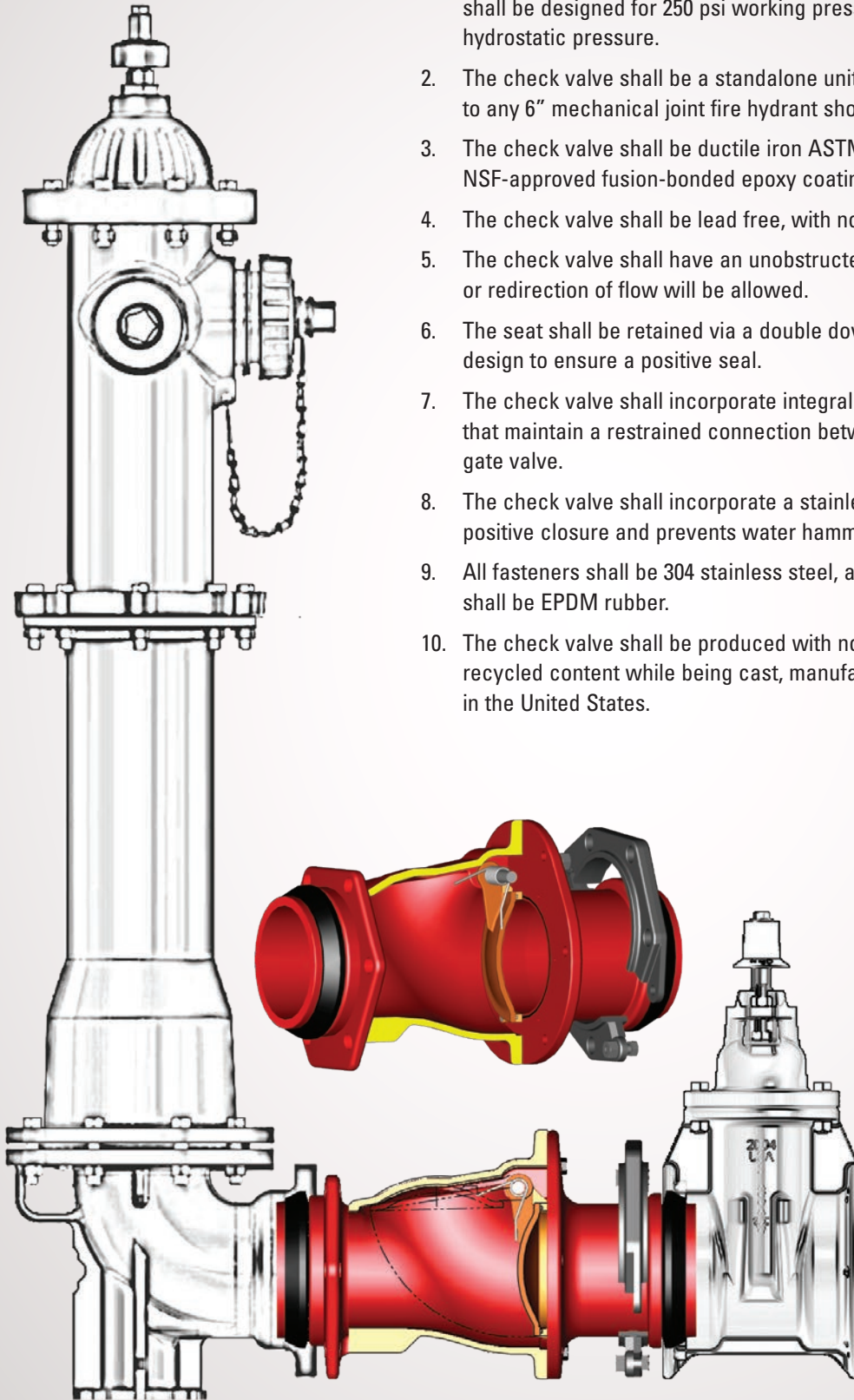

EDDY FIRE HYDRANT

**WHEN PLACING ORDERS OR REQUESTING QUOTES OR SUBMITTALS,
PLEASE SUPPLY THE FOLLOWING INFORMATION:**

- Quantity of hydrants, accessories, and maintenance kits required
- Size of main valve opening: 4 1/2" or 5 1/4"
- Size and number of hose nozzles
- Size and number of steamer nozzles
- Hose and pumper nozzle thread specifications
- Type of inlet connection
- Depth of trench or bury
- Direction of opening
- Size and shape of operating nut and cap nuts
- Color desired
- Municipality name



COMMITTED TO ENVIRONMENTAL RESPONSIBILITY

Clow Valve Company is committed to protecting our natural resources through environmentally responsible manufacturing practices, including the use of 80+% recycled content in our hydrants and valves.



CLOW
VALVE CO.

902 South 2nd Street
Oskaloosa, IA 52577
Ph 641-673-8611
Fx 641-673-8269



POCKET ENGINEER
Available for iOS + Android
or online at pe.mcwane.com.



REVISION A-2019



ClowValve.com