

CLOW Valve Company

902 South 2nd St. Oskaloosa, IA 52577
1-800-829-2569 info@clowvalve.com
www.clowvalve.com

F-2640 Eddy Fire Hydrant

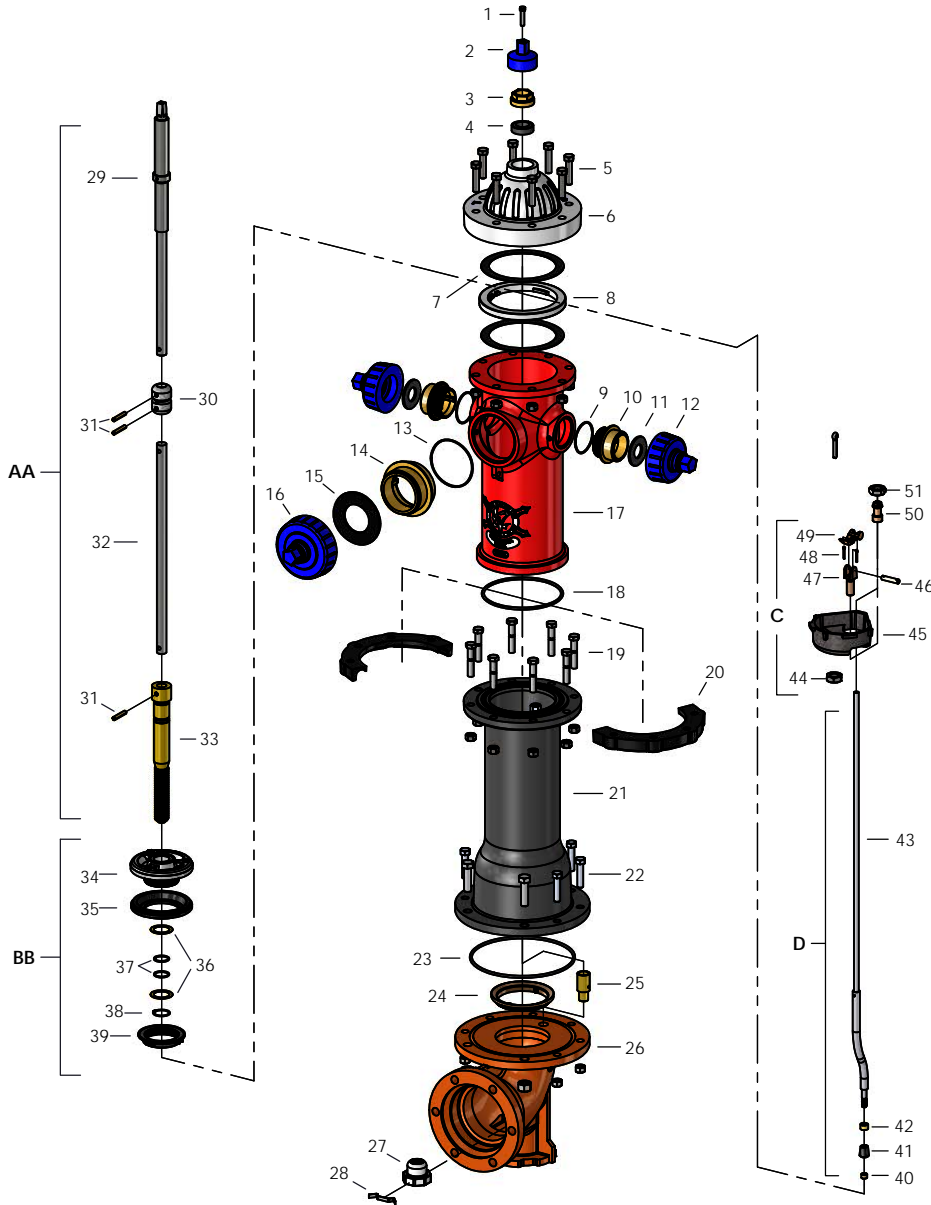

PART NO.	PART	MATERIAL	QTY
1	HOLD DOWN BOLT	STAINLESS STEEL	1
2	OPERATING NUT	CAST IRON	1
3	PACKING GLAND	COPPER ALLOY	1
4	PACKING	POLYMER	1
5	COVER BOLTS & NUTS	STAINLESS STEEL	8
6	COVER	CAST IRON	1
7	GASKET	RUBBER	2
8	SUPPORT RING	CAST IRON	1
9	O-RING	RUBBER	2
10	HOSE NOZZLE	COPPER ALLOY	2
11	HOSE NOZ. GASKET	NEOPRENE	2
12	HOSE NOZ. CAP	CAST IRON	2
13	O-RING	RUBBER	1
14	STEAMER NOZZLE	COPPER ALLOY	1
15	NOZZLE GASKET	NEOPRENE	1
16	NOZZLE CAP	CAST IRON	1
17	NOZZLE SECTION	CAST IRON	1
18	O-RING	RUBBER	1
19	BREAK FLANGE BOLTS & NUTS	YELLOW ZINC STEEL	8
20	BREAK FLANGE	CAST IRON	2
21	STANDPIPE	DUCTILE IRON	1
22	BOTTOM BOLTS & NUTS	STAINLESS STEEL	6
23	O-RING	RUBBER	1
24	SEAT RING	COPPER ALLOY	1
25	DRAIN CAP	COPPER ALLOY	1
26	HYDRANT BOTTOM	DUCTILE IRON	1
27	HYDRANT BOTTOM NUT	COPPER ALLOY	1
28	RETAINING SPRING	STAINLESS STEEL	1
29	UPPER STEM	STAINLESS STEEL & BRASS	1
30	STEM COUPLING	CAST IRON	1
31	COUPLING PINS	STAINLESS STEEL	3
32	MIDDLE STEM	STEEL	1
33	LOWER STEM	COPPER ALLOY	1
34	VALVE PLATE	CAST IRON	1
35	VALVE RUBBER	RUBBER	1
36	THRUST WASHER	COPPER ALLOY	2
37	O-RING	RUBBER	2
38	SNAP RING	STAINLESS STEEL	1
39	THROTTLING RING	COPPER ALLOY	1
40	RETAINING NUT	COPPER ALLOY	1
41	DRAIN VALVE RUBBER	RUBBER	1
42	DRAIN VALVE BACKER	COPPER ALLOY	1
43	DRAIN ROD	STEEL	1
44	CLEVIS NUT	COPPER ALLOY	1
45	DRAIN SUPPORT	CAST IRON	1
46	LEVEL PIN	COPPER ALLOY	1
47	CLEVIS	COPPER ALLOY	1
48	COTTER PIN	STAINLESS STEEL	2
49	DRAIN LEVER	COPPER ALLOY	1
50	DRAIN SPOOL	COPPER ALLOY	1
51	JAM NUT	COPPER ALLOY	1
	CHAIN	ZINC PLATED STEEL	3

WORKING PRESSURE: 250 PSI

	ASSEMBLY	CONSISTING OF PARTS
AA	MAIN STEM (NEW STYLE)	29-33
BB	HYDRANT VALVE (NEW STYLE)	34-39
C	DRAIN SUPPORT	44-49
D	DRAIN VALVE	40-43 50 51
EE	COMPLETE VALVE AND STEM	ASSEMBLIES AA & BB

RECOMMENDED SPECIFICATIONS

- Hydrant shall be center-stem type and in accordance with AWWA Standard C502
- Hydrant shall be compression type with the main valve opening with the water pressure and have a rising stem to positively indicate open or closed position
- Hydrant shall be furnished with frangible break flange and break coupling at the ground line
- Copper Alloy stem threads shall be located below the main valve to eliminate necessity of lubrication; main valve will remain mechanically closed in case of damage to hydrant
- Hydrant shall have minimum valve opening of either 4 1/2" or 5 1/4"; shoe inlet of 4" or 6"
- Hydrant shall be designed to permit removal of all working parts without special tools or wrenches
- Hydrant shall be the Eddy Hydrant, manufactured by Clow Valve Company

CLOW Valve Company

902 South 2nd St. Oskaloosa, IA 52577
1-800-829-2569 info@clowvalve.com
www.clowvalve.com

F-2641 Eddy Hydrant - No Drain

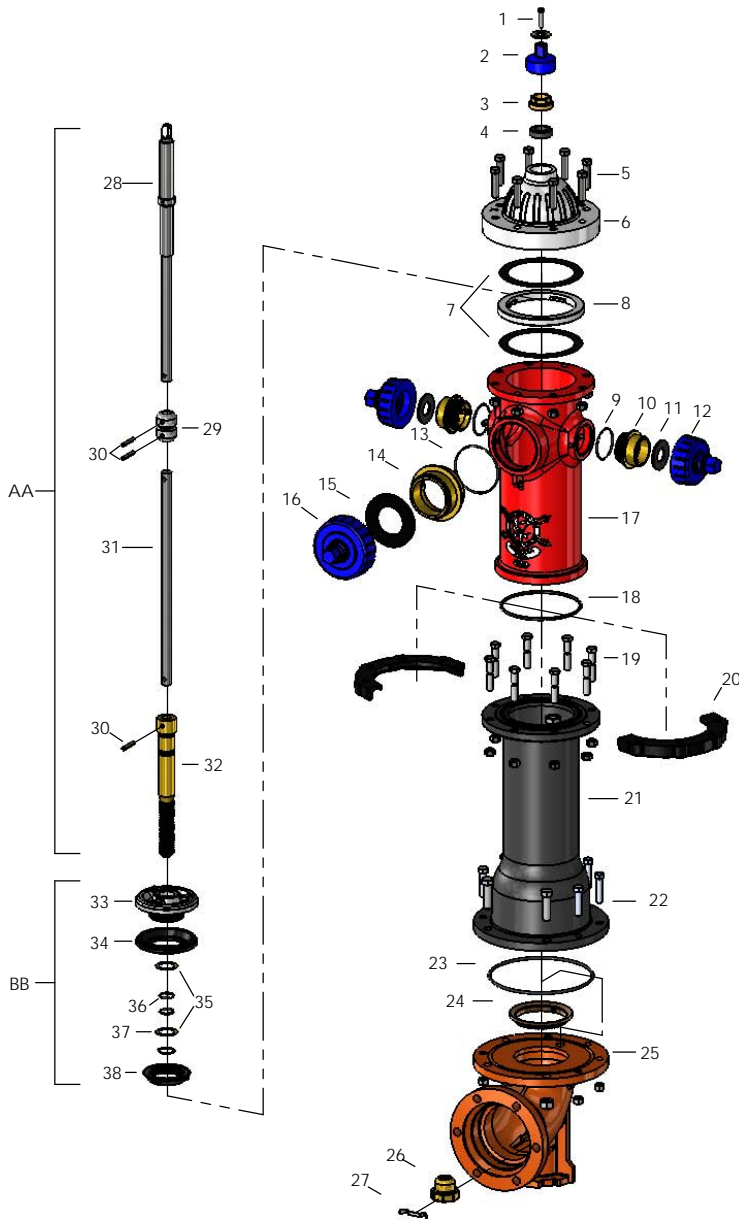

	ASSEMBLY	CONSISTING OF PARTS
AA	MAIN STEM (NEW STYLE)	28-32
BB	HYDRANT VALVE (NEW STYLE)	33-38
EE	COMPLETE VALVE AND STEM	ASSEMBLIES AA & BB

PART NO.	PART	MATERIAL	QTY
1	HOLD DOWN BOLT	STAINLESS STEEL	1
2	OPERATING NUT	CAST IRON	1
3	PACKING GLAND	COPPER ALLOY	1
4	PACKING	POLYMER	1
5	COVER BOLTS & NUTS	STAINLESS STEEL	8
6	COVER	CAST IRON	1
7	GASKET	RUBBER	2
8	SUPPORT RING	CAST IRON	1
9	O-RING	RUBBER	2
10	HOSE NOZZLE	COPPER ALLOY	2
11	HOSE NOZ. GASKET	NEOPRENE	2
12	HOSE NOZ. CAP	CAST IRON	2
13	O-RING	RUBBER	1
14	STEAMER NOZZLE	COPPER ALLOY	1
15	NOZZLE GASKET	NEOPRENE	1
16	NOZZLE CAP	CAST IRON	1
17	NOZZLE SECTION	CAST IRON	1
18	O-RING	RUBBER	1
19	BREAK FLANGE BOLTS & NUTS	YELLOW ZINC STEEL	8
20	BREAK FLANGE	CAST IRON	2
21	STANDPIPE	DUCTILE IRON	1
22	BOTTOM BOLTS & NUTS	STAINLESS STEEL	6
23	O-RING	RUBBER	1
24	SEAT RING	COPPER ALLOY	1
25	HYDRANT BOTTOM	DUCTILE IRON	1
26	HYDRANT BOTTOM NUT	COPPER ALLOY	1
27	RETAINING SPRING	STAINLESS STEEL	1
28	UPPER STEM	STAINLESS STEEL & BRASS	1
29	STEM COUPLING	CAST IRON	1
30	COUPLING PINS	STAINLESS STEEL	3
31	MIDDLE STEM	STEEL	1
32	LOWER STEM	COPPER ALLOY	1
33	VALVE PLATE	CAST IRON	1
34	VALVE RUBBER	RUBBER	1
35	THRUST WASHER	COPPER ALLOY	2
36	O-RING	RUBBER	2
37	SNAP RING	STAINLESS STEEL	1
38	THROTTLING RING	COPPER ALLOY	1
	CHAINS	ZINC PLATED STEEL	3

WORKING PRESSURE: 250 PSI

RECOMMENDED SPECIFICATIONS (EDDY - NO DRAIN)

- Hydrant shall be center-stem type and in accordance with AWWA Standard C502
- Hydrant shall be compression type with the main valve opening with the water pressure and have a rising stem to positively indicate open or closed position
- Hydrant shall be furnished with frangible break flange and break coupling at the ground line
- Copper Alloy stem threads shall be located below the main valve to eliminate necessity of lubrication; main valve will remain mechanically closed in case of damage to hydrant
- Hydrant shall have minimum valve opening of either 4 1/2" or 5 1/4"; shoe inlet of 4" or 6"
- Hydrant shall be designed to permit removal of all working parts without special tools or wrenches
- Hydrant shall be without a drain to prevent the possibility or cross connection
- Hydrant shall be the Eddy Hydrant, manufactured by Clow Valve Company

Eddy Fire Hydrant

CLOW VALVE COMPANY

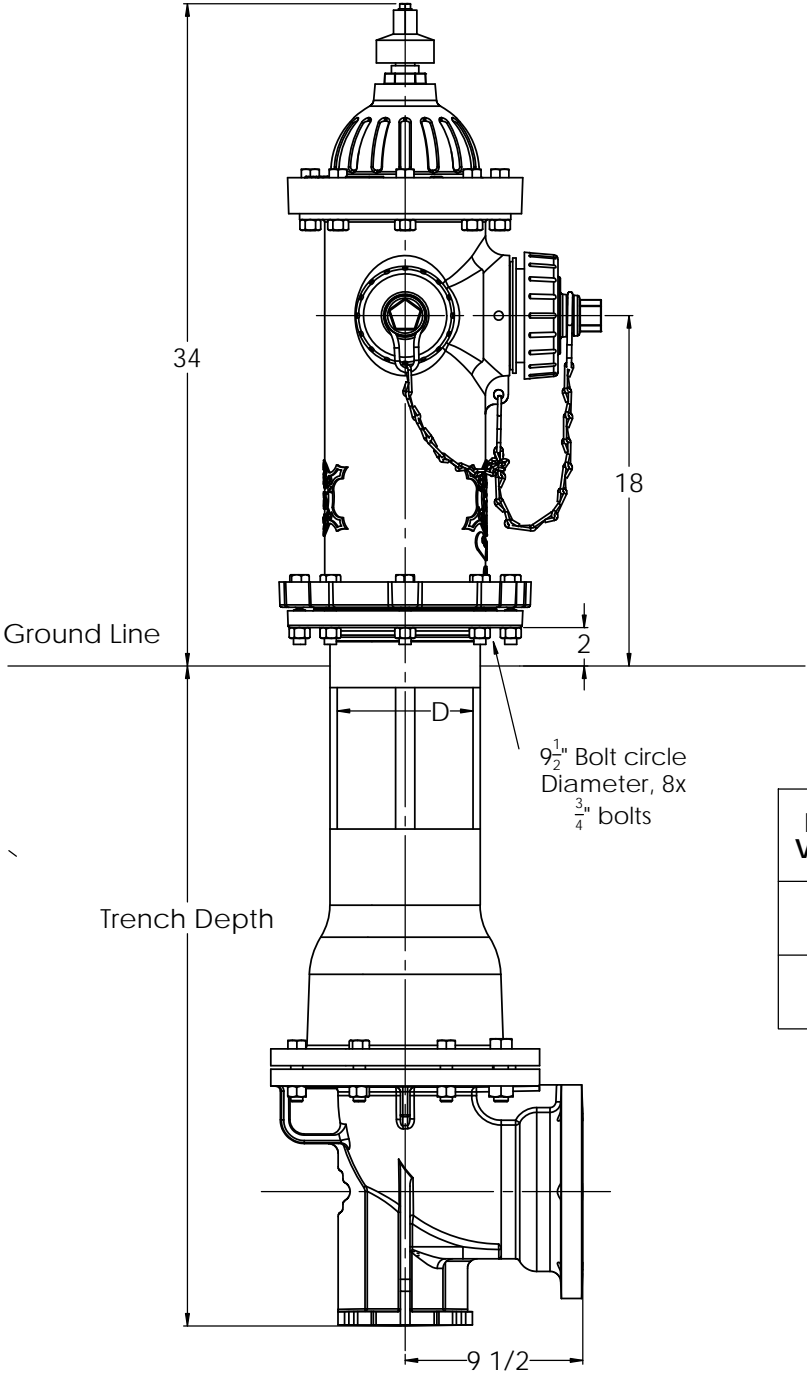

HYDRANT VALVE SIZE	D
4 1/2	6 1/2
5 1/2	7 1/4

SAMPLE SPECIFICATIONS

CLOW VALVE COMPANY

F-2640 & F2641

Eddy with Drain F-2640

Hydrant shall be center stem type and in accordance with AWWA Standard C502-85.

Hydrant shall be compression type with the main valve opening with the water pressure and have a rising stem to positively indicate open or closed position.

Hydrant shall be furnished with frangible break flange and break coupling at the groundline.

Bronze stem threads shall be located below the main valve to eliminate necessity of lubrication and in case of damage to hydrant, main valve will remain mechanically closed.

Hydrant shall have a minimum valve open of either 4¹/₂" or 5¹/₄", and shoe inlet of 4" or 6".

Hydrant shall be designed to permit removal of all working parts without special tools or wrenches.

Hydrant shall have automatic drain, independent of main valve, to provide removal or adjustment without shutting off water, and can be cleaned without clogging.

Hydrant shall be the Eddy Hydrant, manufactured by the Clow Valve Company.

Eddy No Drain F-2641

Hydrant shall be center stem type and in accordance with AWWA Standard C502-85.

Hydrant shall be compression type with the main valve opening with the water pressure and have a rising stem to positively indicate open or closed position.

Hydrant shall be furnished with frangible break flange and break coupling at the groundline.

Bronze stem threads shall be located below the main valve to eliminate necessity of lubrication and in case of damage to hydrant, main valve will remain mechanically closed.

Hydrant shall have a minimum valve open of either 4¹/₂" or 5¹/₄", and shoe inlet of 4" or 6".

Hydrant shall be designed to permit removal of all working parts without special tools or wrenches.

Hydrant shall be without a drain to prevent the possibility of cross connection.

Hydrant shall be the Eddy Hydrant, manufactured by the Clow Valve Company.