

10" C509 FLG X FLG

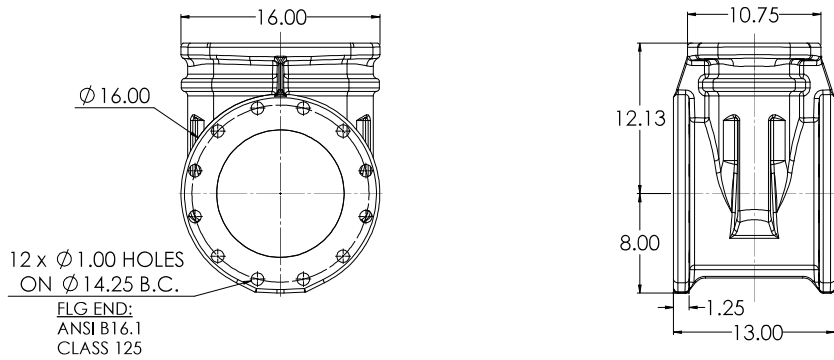

10" C509 MJ X MJ

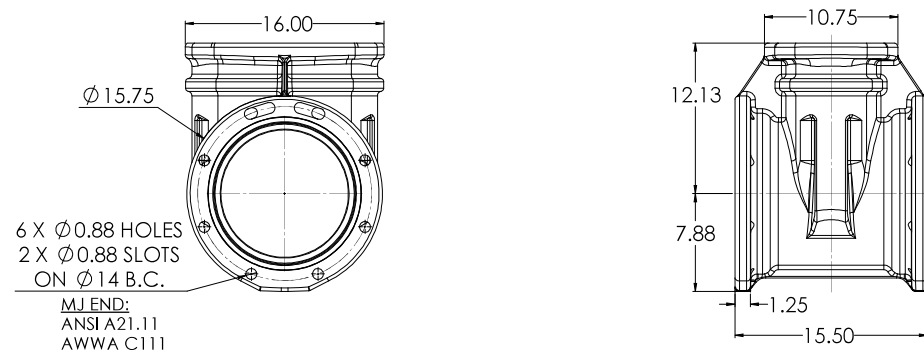

10" C509 FLG X MJ

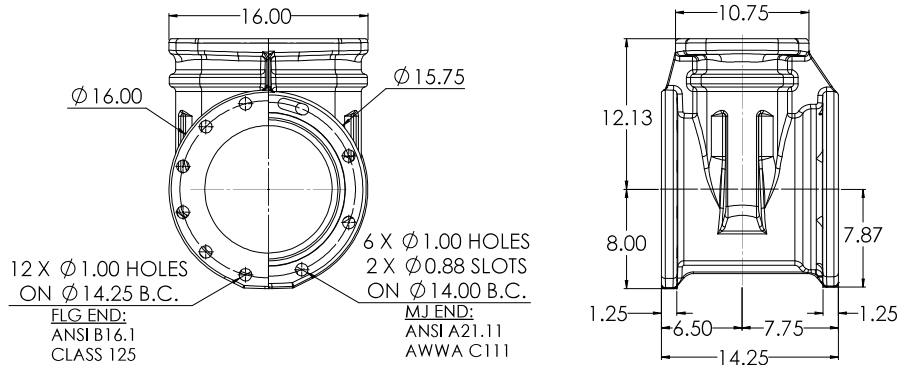

10" C509 MJ X TAP

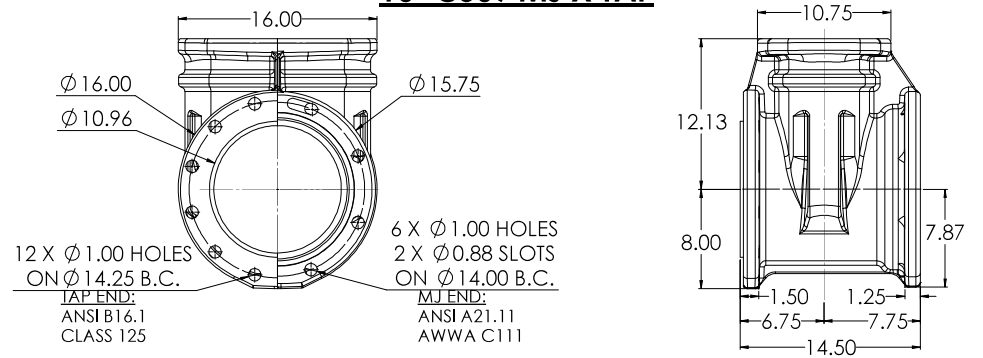

10" C509 TYTON X TYTON

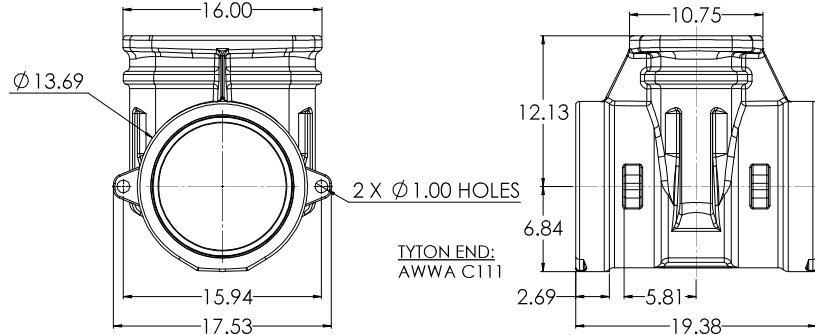

10" C509 PVC X PVC

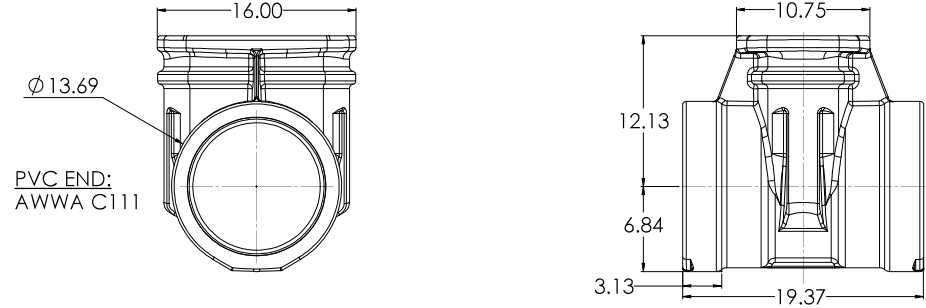

COMPANY: CLW ADDRESS: 1222/2020 PHONE: 714-942-1111 FAX: 714-942-1112 EMAIL: info@clw.com	PROJECT: 10" C509 CS&Y RESILIENT WEDGE GATE VALVE SHEET NO: 6 DATE: 12/2/2020	DRAWN BY: [Signature] CHECKED BY: [Signature] APPROVED BY: [Signature]	SCALE: 1:5 PROJECT NO: SW-2018-SP2
---	---	--	---------------------------------------

10" C509 FLG X TYTON

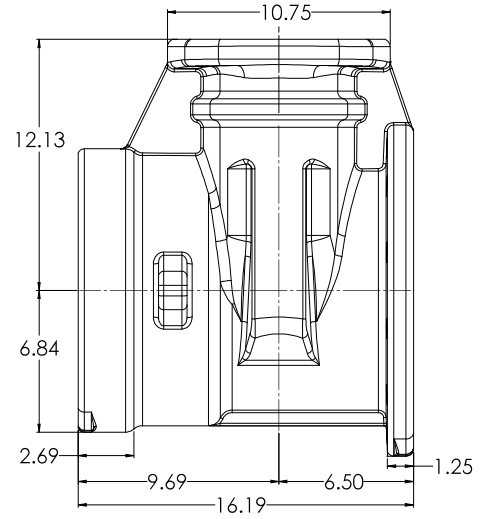
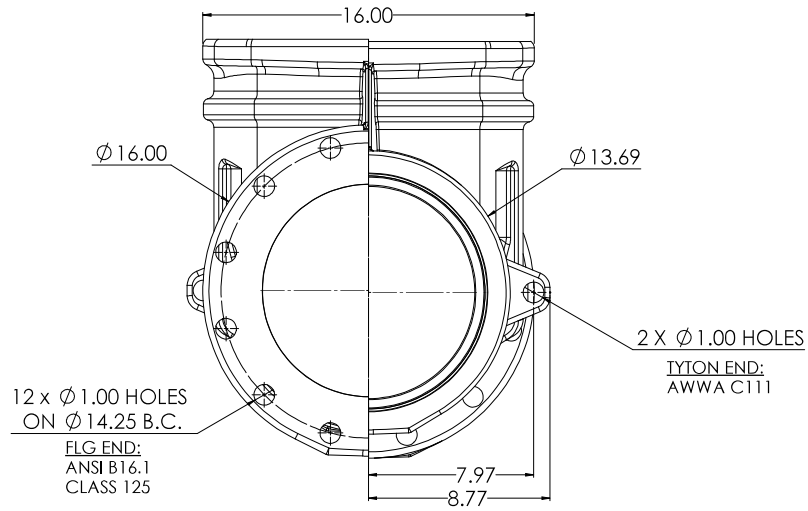

CLW CONSULTING ENGINEERS 1000 W. 10th Street, Suite 100 Lincoln, NE 68502 (402) 441-1111 www.clw-engineers.com		PROJECT NO. 19-001 SHEET NO. 2 OF 6 DATE 12/2/2020		DRAWN BY: J. B. BROWN CHECKED BY: J. B. BROWN DATE: 12/2/2020		PROJECT: 10" C509 CS&Y RESILIENT WEDGE GATE VALVE SCALE: 1:5 SHEET: 2 OF 6		PROJECT: 10" C509 CS&Y RESILIENT WEDGE GATE VALVE SCALE: 1:5 SHEET: 2 OF 6	
--	--	--	--	---	--	--	--	--	--

OS&Y WITH HANDWHEEL

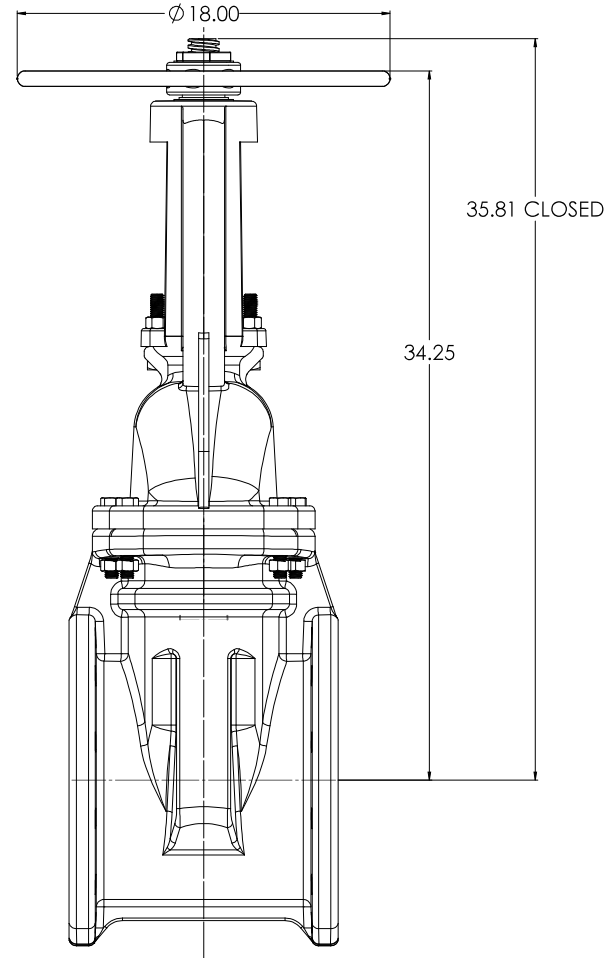
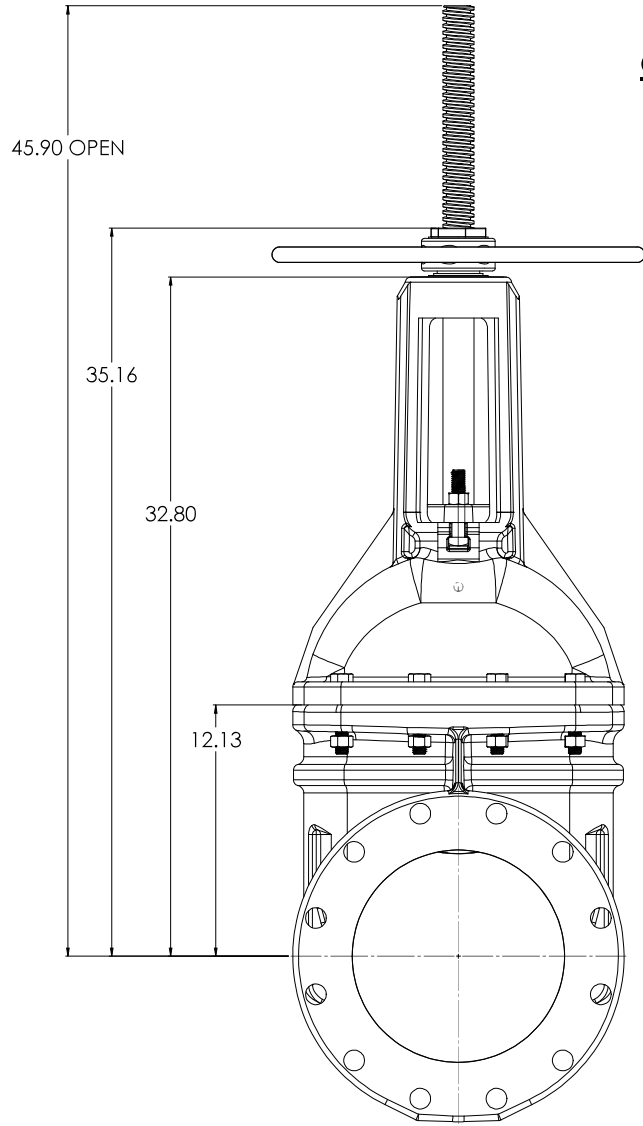

COMPANY: CLW ADDRESS: 10000 W. 10th Ave., Suite 100 Denver, CO 80202 PHONE: (303) 751-1000 FAX: (303) 751-1001 WWW: www.clw.com		PROJECT: 10' OS&Y RESILIENT WEDGE GATE VALVE DRAWING NO: 10' OS&Y RESILIENT WEDGE GATE VALVE DATE: 12/2/2009 DRAWN BY: CW CHECKED BY:		SHEET NO: 3 TOTAL SHEETS: 6 SCALE: T:10 PROJECT NO: 2016 SPZ		CLW 10' OS&Y RESILIENT WEDGE GATE VALVE
--	--	---	--	---	--	--

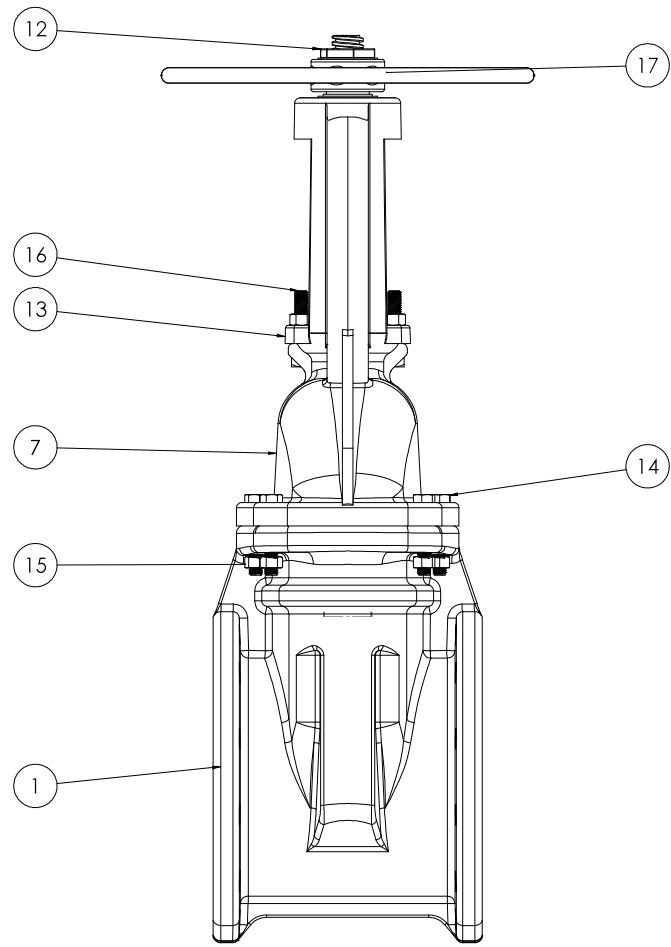
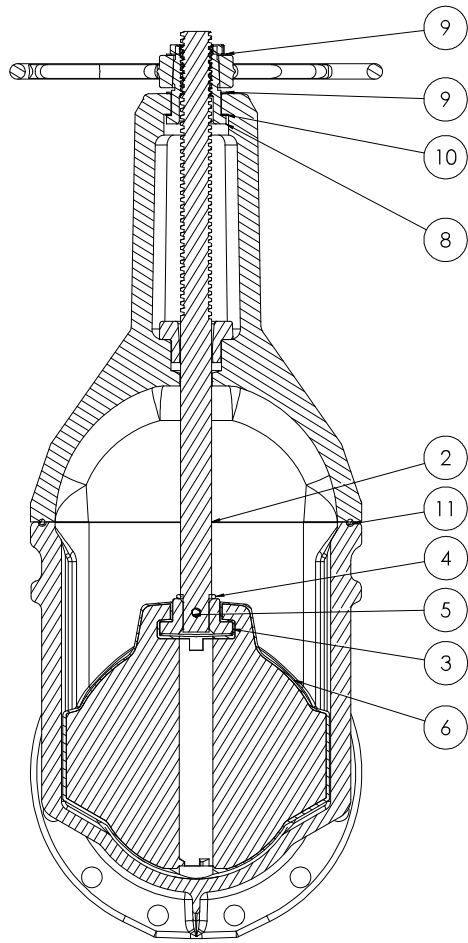

COMPANY: CLW ADDRESS: 12272000 PHONE: 1-800-368-2727 FAX: 1-800-368-2727 E-MAIL: sales@clw.com WEBSITE: www.clw.com		DIVISION: 10' C509 CS&Y RESILIENT WEDGE MODEL: GATE VALVE SIZE: 10" WEIGHT: 100 MATERIAL: CS		DRAWING NO.: 12272000 REV: 1 DATE: 12/2/2000 SCALE: T:10 SHEET NO.: 4 TOTAL SHEETS: 6		PROJECT NO.: PROJECT NAME: CLIENT: DRAWN BY: CHECKED BY: APPROVED BY: DATE:	DRAWN BY: CHECKED BY: APPROVED BY: DATE:	CLW 12272000
--	--	--	--	--	--	---	---	------------------------

