

**06" C509 FLG X FLG**

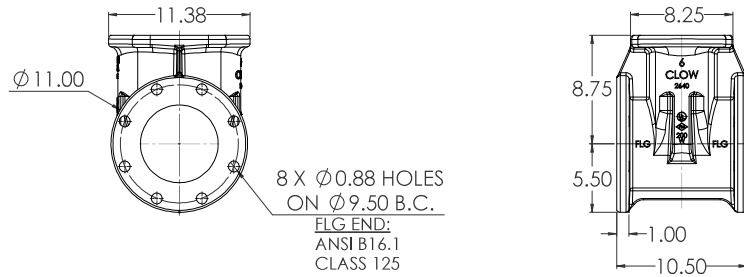

**06" C509 FLG X TYTON**

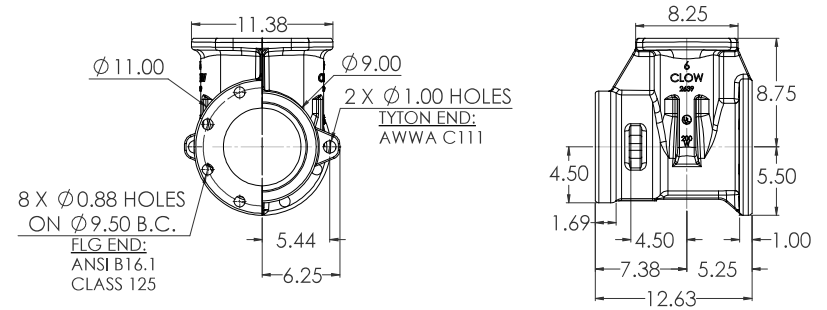

**06" C509 FLG X MJ**

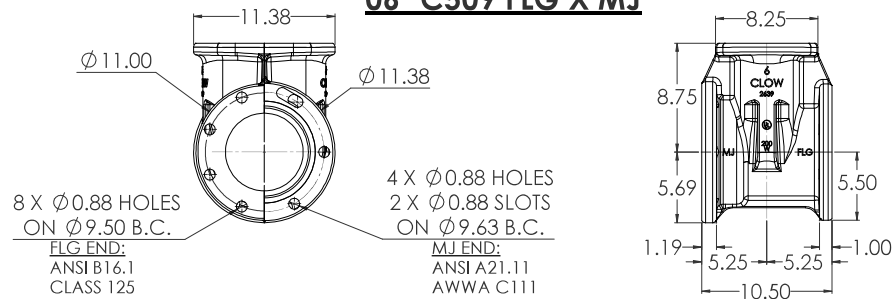

**06" C509 MJ X MJ**

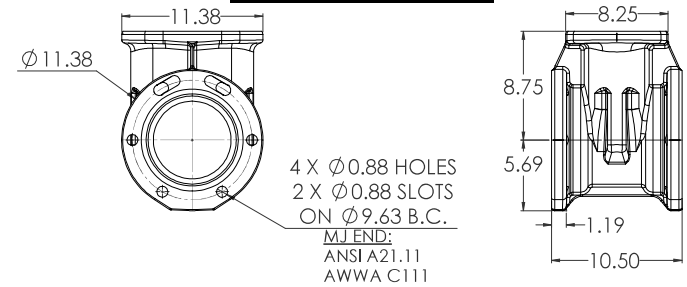

**06" C509 TYTON X TYTON**

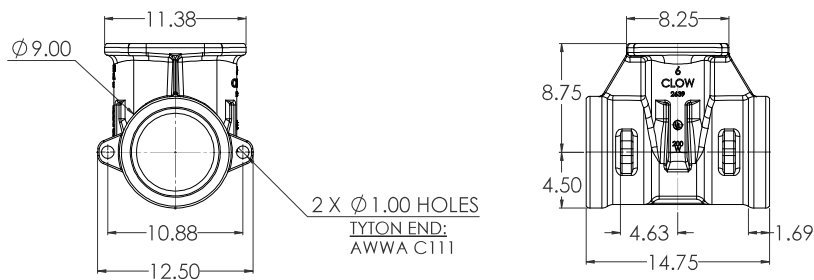

**06" C509 PVC X PVC**

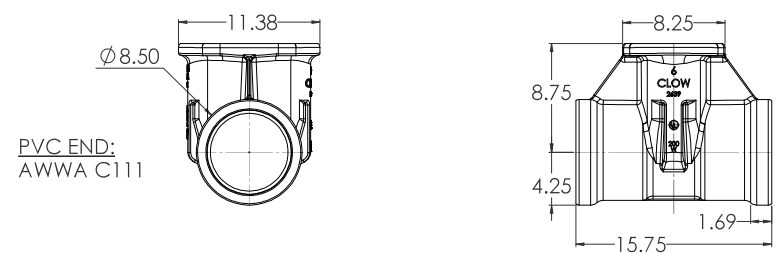

<b>REVISED</b> (DATE) (BY) (REASON) 1 0.01/2020 CW		06" C509 CS&Y RESILIENT WEDGE LBS. GATE VALVE	SHEET NO. 6 OF 6	<b>CLW</b> 125125 00
--	--	--	---------------------	-------------------------







